

AMETEK[®]
MATERIALS ANALYSIS DIVISION

Mini-X X-Ray Tube

50 kV



Amptek, Inc.
14 DeAngelo Drive
Bedford, MA 01730

+1 781 275 2242
Fax: +1 781 275 3470

www.amptek.com
Send sales and technical questions to sales@amptek.com

The Mini-X is based on the Newton Scientific Inc. miniature X-ray source.

Table of Contents

1	Precautions.....	3
1.1	High Voltage.....	3
1.2	Radiation.....	3
1.3	Beryllium Window.....	3
1.4	Heat and Temperature.....	4
2	Overview of the Mini-X X-Ray Tube System for Portable XRF.....	4
2.1	Output X-Ray Spectra.....	5
2.2	Collimator.....	5
2.3	Brass Safety Plug.....	5
2.4	Interlock.....	6
2.5	Filters.....	7
2.6	Mounting.....	7
2.7	Cooling.....	7
3	Software and USB Driver Installation.....	8
3.1	Application Software.....	8
3.2	USB Driver.....	8
4	Operation of the Mini-X.....	8
4.1	Step by Step Instructions.....	8
5	Radiation Levels and Example Shielding.....	10
6	Specifications.....	12
7	Mechanical Dimensions.....	13
8	Application Note: Understanding the Interlock and Alarm.....	14

1 Precautions

CAUTION: The Mini-X is only one component of an X-ray instrument. It is the responsibility of the user, the OEM customer, or experimenter to provide a fail safe metal enclosure to prevent escaping radiation while using this product. The final product (turn-key system) must comply with local government regulations to protect personnel from exposure to radiation. Amptek Inc., bears no responsibility for the incorrect use of this product.

1.1 High Voltage

The Mini-X is designed to generate voltages up to 50 kV. The high voltage system is fully shielded inside the Mini-X enclosure.

DO NOT ATTEMPT TO ACCESS OR MODIFY THE HIGH VOLTAGE SYSTEM.

**DO NOT UNSCREW ANY OF THE SCREWS AT THE NECK OF THE TUBE.
TAMPERING WITH THESE SCREWS WILL VOID WARRANTY.**



Caution

This device produces **HIGH VOLTAGE** when energized.
To be operated only by qualified personnel.



The Mini-X contains a high voltage power supply. High voltage is not exposed, but the Mini-X should still be grounded as a precaution. It should be mounted to a metal fixture via the provided brackets.

The high voltage power supply has been thoroughly tested and should not ever arc to its own case. However, if at any time any high voltage arcing or popping is heard, immediately discontinue use. High voltage arcing has a distinctive sharp cracking sound. Contact sales (sales@amptek.com) if you suspect that the power supply is arcing.

1.2 Radiation

The Mini-X product is intended to generate X-ray radiation during normal operation. The Mini-X has been designed to focus radiation in the designated output direction, however radiation in other directions is possible and should be addressed with shielding and/or monitoring in the final application.



Caution

This device produces **X-RAYS** when energized.
To be operated only by qualified personnel.



Radiation levels external to the X-ray tube housing with the brass safety plug ON do not exceed 2.5 mrem/h measured 5 cm from the surface of the housing in accordance with Requirements 5.2.2.1.1 and 5.2.2.2.2 of the NBS Handbook for Radiation Safety for X-Ray Diffraction and Fluorescence Analysis Equipment. For more information please see <http://epswww.unm.edu/xrd/nbs111.pdf>.

1.3 Beryllium Window

When unpacking the Mini-X pay careful attention to the Beryllium (Be) window on the front of the unit. This is a fragile window which can be damaged by impact. Beryllium (silver/gray and metallic) and beryllium oxide dust (normally a whitish powder) are harmful if inhaled or ingested.

AVOID ALL CONTACT WITH THIS PART OF THE X-RAY TUBE.

1.4 Heat and Temperature

The ambient temperature surrounding the X-ray tube must not exceed 50 °C. Improper cooling is the single highest cause of X-ray tube failures and is not covered under the Mini-X Warranty. It is the user's responsibility to provide an adequate cooling system for the Mini-X.

2 Overview of the Mini-X X-Ray Tube System for Portable XRF

Important – Read the precautions in Section 1 of this manual before operating this equipment.

Mini-X is the first of its kind; a self-contained, packaged, miniature X-ray tube system, which includes the X-ray tube, the power supply, the control electronics and the USB communication to the computer. It is designed to replace radioisotopes in X-ray fluorescence analysis applications.

Mini-X has been designed to simplify the XRF process by providing a grounded anode, variable current and voltage controlled via USB and ease of operation. It features a 50 kV/80 μ A power supply, a gold (Au) or silver (Ag) transmission target, and a beryllium end window. A collimator and various filters are also provided. It is designed for continuous operation in industrial environments.

To further simplify the use of Mini-X an AC adaptor is provided to supply the 12 VDC needed to power the system. The only connections needed to operate the tube are a USB cable and AC adaptor. A flashing red LED and a beeper warns the user when x-rays are present.



Figure 1. Complete XRF System. The Mini-X together with the X-123 complete spectrometer.

2.1 Output X-Ray Spectra

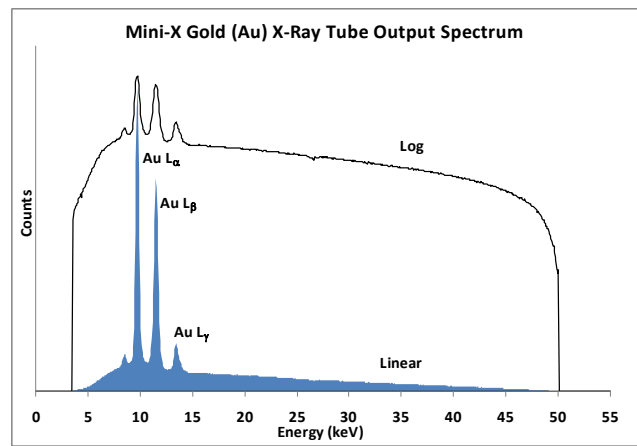
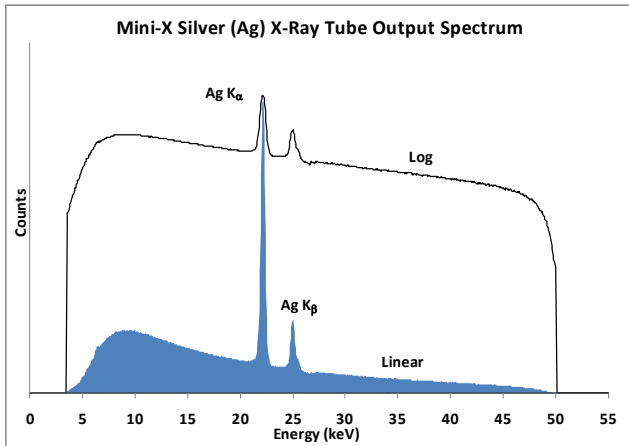

Figure 2. Output Spectrum with silver (Ag) target. Figure 3. Output Spectrum with gold (Au) target.

2.2 Collimator

The Mini-X is provided with two collimators to facilitate its use in XRF applications. They consist of a brass collimator with aluminum (Al) inserts and a cover that screws into the Mini-X. The collimators have 1 and 2 mm diameter holes. A brass safety plug is also provided which, when installed, reduces the flux from an operating tube to less than 25 $\mu\text{Sv/h}$ (2.5 mrem/hr) at 5 cm away in accordance with Requirements 5.2.2.1.1 and 5.2.2.2.2 of the NS Handbook for Radiation Safety for X-Ray Diffraction and Fluorescence Analysis Equipment. Insert the collimator into the cover and then carefully screw the assembly onto the Mini-X. The collimator has a 2 mm diameter hole.



Figure 4. Left photo shows the Mini-X collimators, safety plug, and cover. The middle photo shows the safety plug installed in the cover and attached to the Mini-X. This configuration meets the radiation requirements discussed in Section 1.2. The Mini-X ships from the factory in this configuration. The right photo shows the collimator installed in the cover.

2.3 Brass Safety Plug

When the brass safety plug is installed in the cover (figure 4, middle) and screwed onto the Mini-X it meets the radiation safety requirements of Section 1.2. For personal protection always install the safety plug into the cover and attach to the Mini-X when not in use. The Mini-X ships from the factory in this configuration.

2.4 Interlock

The Mini-X has a hardware interlock in order to prevent accidental exposure. This interlock must be shorted (enabled) in order for the Mini-X to produce X-rays. The left figure below shows the interlock disabled. The Mini-X will not produce X-rays in this configuration. The right figure shows the interlock enabled. The Mini-X will produce X-rays in this configuration. Always store the Mini-X with the interlock disabled when not in use.



Figure 5. Showing the interlock disabled (left) and enabled (right).

One of the primary purposes of the interlock is so that the user can interface to external safety mechanisms. This is most commonly implemented as a shutter or cover that, when opened, disables the interlock and stops the generation of X-rays. When the tube is producing X-rays and the interlock is disabled, the tube will go into a reset mode. It is therefore necessary to restart the tube through software. Re-enabling the interlock after disabling it will not resume the production of X-rays.

The figure below is a block diagram of the Mini-X power and control interface, illustrating the use of the “Interlock” connector. This connector has two functions: it permits the user to implement a safety interlock, which turns off the X-ray tube when a switch is opened, and it permits the user to implement an external indicator to show when the tube is in use.

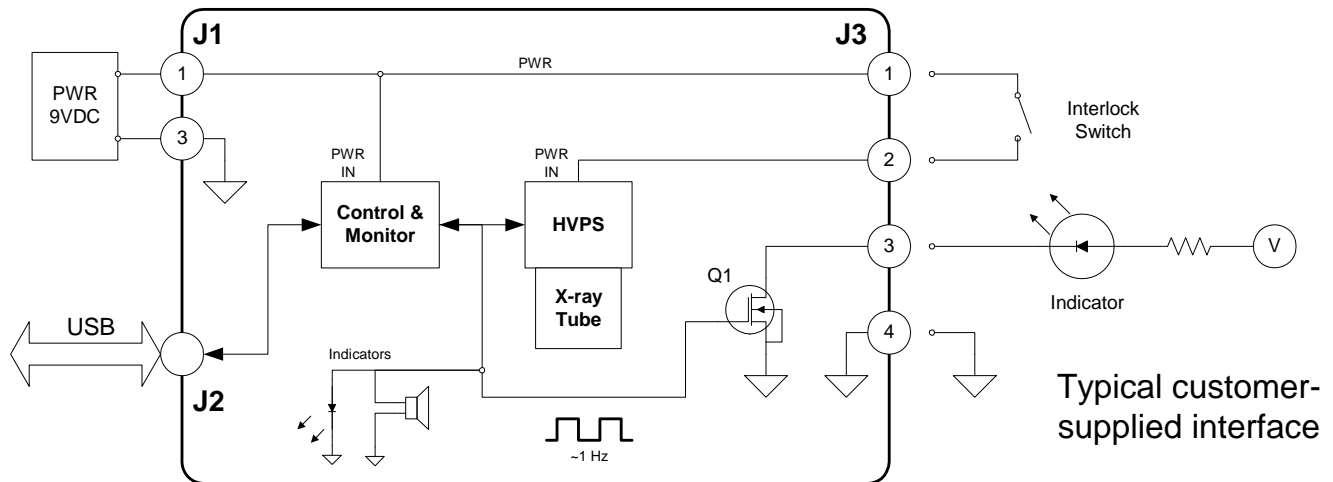

Figure 6. Power and control interface.

As shown in the figure, power is supplied to the high voltage power supply (HVPS) via a connection between pins 1 and 2 of the interlock connector. If the connection between these pins is interrupted, there is no power to the HVPS and so the tube turns off. In addition, this latches a bit in the monitor circuit, which must be reset via a USB command. When a connection is restored between pins 1 and 2, although power is restored to the HVPS, the unit is not turned on until this command is received. The voltage at pins 1 and 2 is typically 9VDC. As shown in the figure, a user could connect this to a switch, typically located on the cover of the enclosure housing the X-ray target. If a user accidentally

opens the cover without first turning off the tube, this will automatically turn off the power, preventing accidental radiation exposure.

The Mini-X contains a speaker and an LED, both of which indicate that the X-ray tube is turned on. The LED is visible on the back side of the Mini-X package, but in some applications the Mini-X is inside an enclosure. Pins 3 and 4 can be used to drive an external indicator, such as the LED sketched above. The user must provide the circuit interfacing to pins 3 and 4. Q1 is an N-channel enhancement mode MOSFET, part number ZXM61N02FTA. Key ratings are VDSS=20V (absolute max) and ID=1.7A (absolute max, 25 °C). The gate of the FET is driven by a square wave at approximately 1 Hz, 10% duty cycle.

2.5 Filters

The Mini-X is shipped with a set of filters to modify the output spectrum of the tube to better suite a particular application. The use of any filter will reduce the flux, so the current may have to be increased to obtain an appropriate flux. Install the filter at the Mini-X screw base. Then screw on the cover with the collimator. Make sure that the cover screws all the way down, otherwise radiation will leak through the gap. All filter thicknesses will fit except for the 40 mil Al. This filter must be installed on the outside output aperture of the collimator and held in place with the black cap provided.

Material	Thickness μm/mils	# Included
Al	1016 / 40	5
Al	254 / 10	5
Cu	25.4 / 1	3
Mo	25.4 / 1	2
Ag	25.4 / 1	1
W	25.4 / 1	1

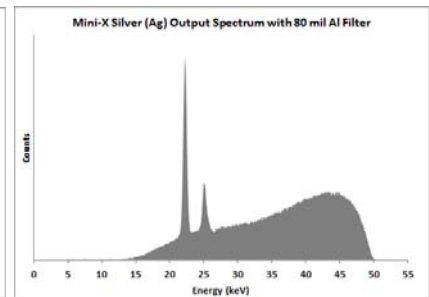
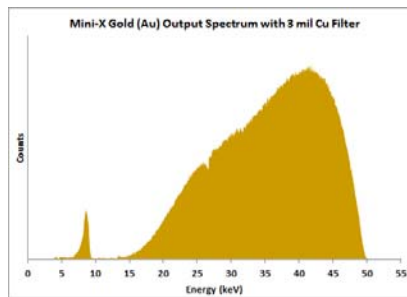

2.6 Mounting

The Mini-X can be fastened to any surface by using the mounting holes and brackets that are provided.

2.7 Cooling

The Mini-X requires proper and adequate cooling for maximum life. As such, it is the user's responsibility to provide a cooling design, such that the ambient temperature around the X-ray tube does not exceed 50 °C. Air cooling via a small fan is recommended. Improper cooling is the single highest cause of X-ray tube failures. Improper cooling is not covered under the warranty.

The maximum operating temperature of the Mini-X is 50 °C. The Temperature Sensors on the left side show the Mini-X exceeded 54 °C. This voids warranty.

Dark circles indicate operating temp >54 °C



3 Software and USB Driver Installation

Do not plug in the Mini-X until you have first installed the Application Software. This process will also copy the USB drivers to your computer so that USB driver installation is easier.

3.1 Application Software

Locate the Mini-X folder on the Amptek Installation CD. Run the “Mini-X Setup.exe” file.

1. When the dialog opens click Next.
2. Click Install.
3. Click Finish.
4. Another Wizard will open.
5. Click Next.
6. Click Finish.

3.2 USB Driver

This procedure must be performed for every unique Mini-X (i.e. different serial number) that is connected to the computer. The Mini-X USB interface contains two internal controllers, A and B. This means that two USB drivers must be installed for each Mini-X. Perform the steps below for both Mini-X Controller A and Mini-X Controller B. When a new Mini-X is connected, Windows will prompt for the drivers to be installed.

1. Select “Install from a list or specific location (Advanced)” and then click Next.
2. Select “Don’t Search. I will select the driver to install” and then click Next.
3. Select Mini-X Controller A then click Next.
4. Click "Continue Anyway" to install the drivers. Repeat for Controller B.

4 Operation of the Mini-X

X-rays exit the Mini-X in an 120 degree cone. NOTE: When using the 2 mm collimator, the X-ray cone is 5°.

**SAFETY PRECAUTIONS MUST BE USED FOR
EQUIPMENT THAT PRODUCE X-RAYS.
MINIMIZE HUMAN EXPOSURE TO X-RAYS.
USE A GEIGER COUNTER TO MONITOR RADIATION.
STOP: ONLY QUALIFIED PERSONNEL SHOULD
PROCEED BEYOND THIS POINT.**

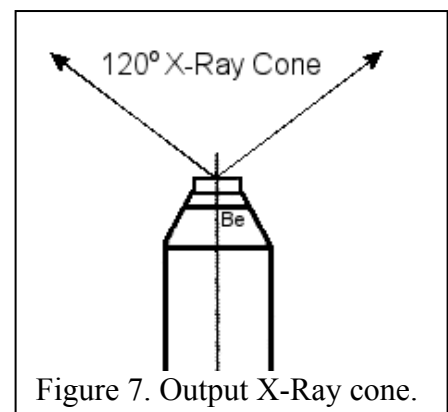

4.1 Step by Step Instructions

1. Install the software as described in Section 3.
2. Connect the Mini-X to the PC computer with the USB cable.
3. Connect the AC power adapter to the Mini-X and plug it into an appropriate 110/220 AC power outlet.

4. Remove the safety plug from the cover attached to the Mini-X. Either install the collimator into the cover or leave the cover empty. Re-attach the cover to the Mini-X.
5. Make sure that you have verified the anticipated direction of the X-ray beam as described above.
6. The Mini-X has a hardware interlock in order to prevent accidental exposure. This interlock must be shorted (enabled) in order for the Mini-X to produce X-rays. Install the interlock plug to enable the Mini-X to produce X-rays.
7. Open the Amptek Mini-X Controller Software. It will appear as below.

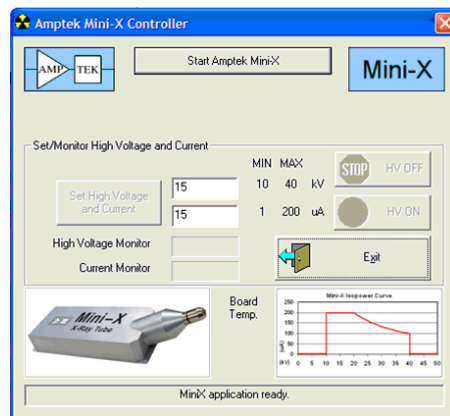

Figure 8.

8. Click the Start Amptek Mini-X button. The software will display the serial number of the unit.

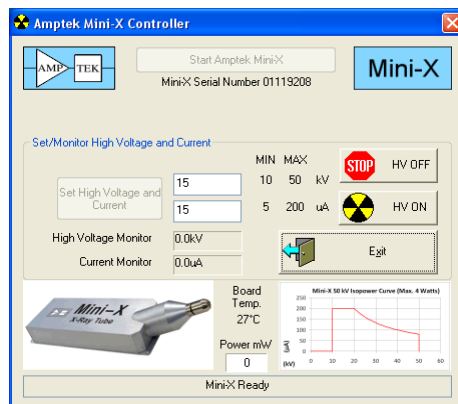

Figure 9.

9. The software defaults to a setting of 15 kV and 15 μ A. To change the values click into the appropriate text box and type in the desired number.

IMPORTANT: Do not enter a voltage higher than 50 kV. In addition, the total power of the Mini-X is governed by the Isopower curve. Do not enter a current that exceeds the indicated value for that voltage. If a requested current is too high, the software will automatically adjust it to the maximum allowed value.

10. Click the HV ON button to turn on the tube. The software will ask you to confirm. Click Yes.



THE MINI-X IS NOW PRODUCING X-RAYS



11. The Mini-X will start to beep and the red LED on the end panel of the unit will flash. In addition the yellow and black “Radiation Symbol” will blink in the Mini-X Software and the words “X-Ray ON” will appear.

For your safety and for the safety of others, the Beeper should be left ON AT ALL TIMES.

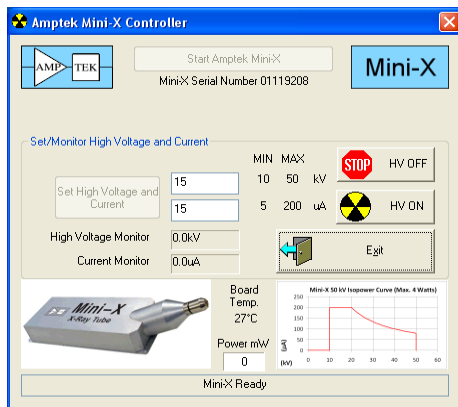

Figure 10.

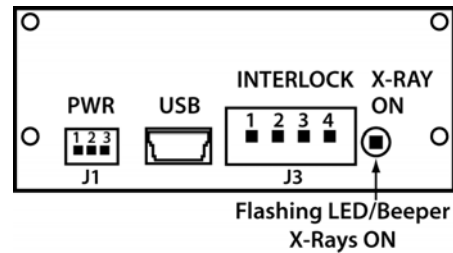

Figure 11.

12. The Voltage and Current monitors now show the actual X-ray tube condition. Although the values for Voltage and Current might be slightly different from the requested values, these are the actual values of the tube.
13. To change the high voltage and current, click into the appropriate text box and enter the number. Then click the Set High Voltage and Current button.
14. To turn off the Mini-X click the HV OFF button, then click the Exit button to exit the software. Always unplug the Mini-X, install the safety plug, and disable the interlock when not in use.

5 Radiation Levels and Example Shielding

Radiation levels external to the X-ray tube housing with the brass safety plug ON do not exceed 25 $\mu\text{S/h}$ (2.5 mrem/h) measured 5 cm from the surface of the housing in accordance with Requirements 5.2.2.1.1 and 5.2.2.2.2 of the National Bureau of Standards (NBS) Handbook for Radiation Safety for X-Ray Diffraction and Fluorescence Analysis Equipment.

For more information please see the NBS Handbook.

Examples of Shielding (that comply with the above standard)

- 1 mm (0.040 inch) of Pb will result in radiation levels of 0.5 mrem/h.
- 6.35 mm (0.250 inch) of Fe will result in radiation levels of 0.5 mrem/h.
- 3.18 mm (0.125 inch) of Brass will result in radiation levels of 2.5 mrem/h.

The inside of the housing can also be lined with 3.18 mm (0.125 inch) of aluminum (Al) in order to absorb the XRF from the shielding material.

CAUTION: The Mini-X is only one component of an X-ray instrument. It is the responsibility of the user, the OEM customer, or experimenter to provide a fail-safe metal enclosure to prevent escaping radiation while using this product. The final product (turn-key system) must comply with local government regulations to protect personnel from exposure to radiation. Amptek Inc., bears no responsibility for the incorrect use of this product.

6 Specifications

	Silver (Ag) Target	Gold (Au) Target
Target Thickness	0.75 μm ($\pm 0.1 \mu\text{m}$)	1 μm ($\pm 0.1 \mu\text{m}$)
Tube Voltage	10 to 50 kV	10 to 50 kV
Tube Current	5 μA min. / 200 μA max.	5 μA min. / 200 μA max.
Approximate Dose Rate	1 Sv/h @ 30 cm on axis, 50 kV and 80 μA	1.3 Sv/h @ 30 cm on axis, 50 kV and 80 μA
Approximate Flux	10^6 counts per second/ mm^2 on the axis at a distance of 30 cm (50 keV/1 μA)	1.3×10^6 counts per second/ mm^2 on the axis at a distance of 30 cm (50 keV/1 μA)
Continuous Power	4 W max. @ 100% duty cycle	4 W max. @ 100% duty cycle
Window Material	Beryllium (Be); window at ground	Beryllium (Be); window at ground
Window Thickness	127 μm	127 μm
Focal Spot Size	Approximately 2 mm	Approximately 2 mm
Output Cone Angle	120°	120°
Cooling	Air cooled	Air cooled
High Voltage Stability	< 0.1%	< 0.1%
Leakage Radiation	<5 $\mu\text{Sv/h}$ (0.5 mrem/h) at 5 cm with safety plug installed	<5 $\mu\text{Sv/h}$ (0.5 mrem/h) at 5 cm with safety plug installed
Power Consumption	9 W at 50 kV and 80 μA	9 W at 50 kV and 80 μA
Input Voltage	12 VDC (AC adapter included)	12 VDC (AC adapter included)
Control	USB, mini-USB connector (cable included)	USB, mini-USB connector (cable included)
Setting Time	Typical < 1 s	Typical < 1 s
Weight	360 g	360 g
Humidity	30 to 90% non condensing	30 to 90% non condensing
Operating Temperature	-10 °C to +50 °C	-10 °C to +50 °C
Storage Temperature	-25 °C to +60 °C	-25 °C to +60 °C
Safety Controls and Indicators	1) External hardware interlock 2) Flashing LED 3) Beeper	1) External hardware interlock 2) Flashing LED 3) Beeper
Software	Mini-X Control Software controls voltage and current. Mini-X API for custom programming applications.	Mini-X Control Software controls voltage and current. Mini-X API for custom programming applications.
Warranty	One year or 2000 hours, whichever comes first	One year or 2000 hours, whichever comes first

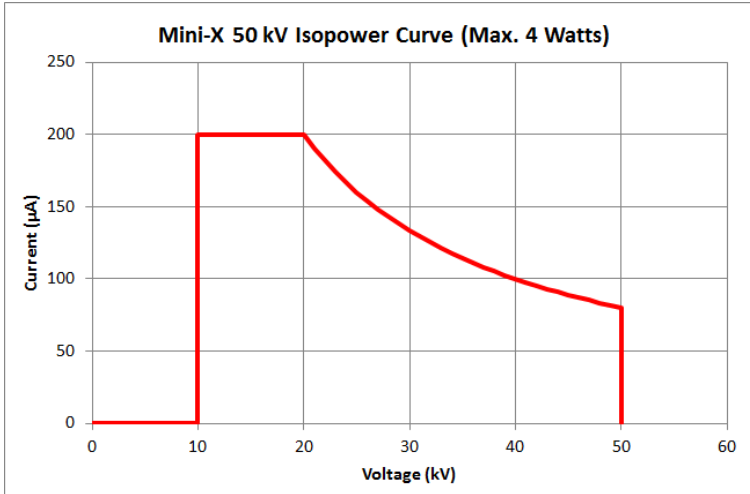

Figure 12. Mini-X Isopower curve. The current and voltage must be set in accordance with this curve or the Mini-X may be severely damaged. Damage of this kind is not covered under warranty.

7 Mechanical Dimensions

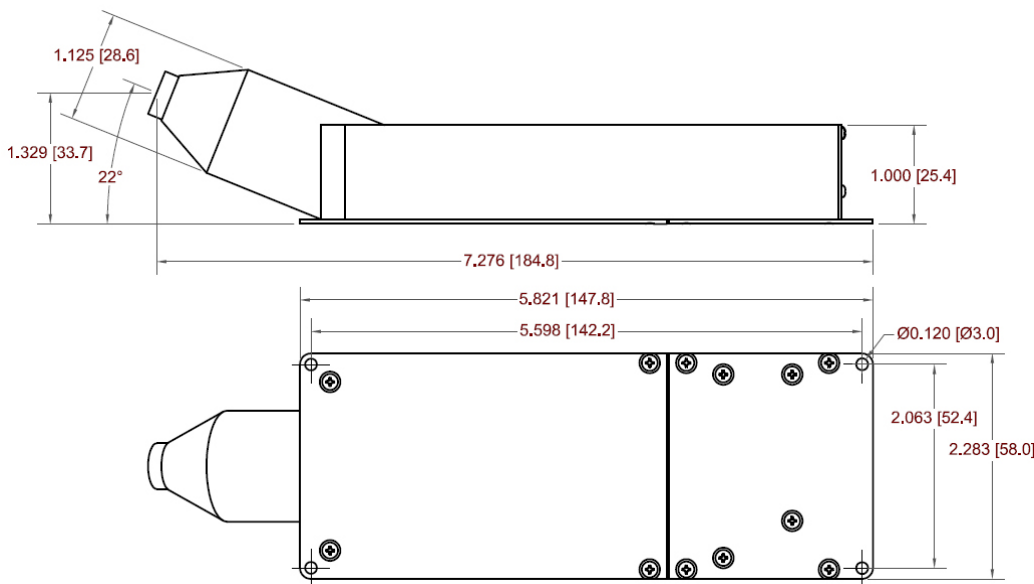

Figure 13. Mini-X mechanical dimensions in inches [mm].

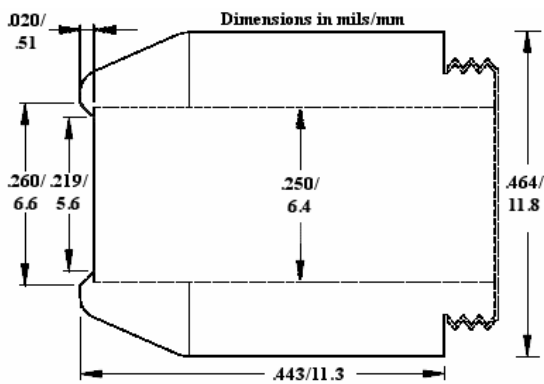

Figure 14. Brass cover dimensions (in mils/mm).

8 Application Note: Understanding the Interlock and Alarm

Safety is an important consideration with the Mini-X X-ray tube. Two key elements in the safety system include the interlock and the alarm (the light and the beeper).

As sketched in Fig. 6, the Mini-X includes three main components: (a) the X-ray tube, (b) a High Voltage power supply (HVPS) and (c) the control and monitor circuit. The interface between the high voltage power supply and the control circuit is critical to understanding the interlock system. Fig. 15 below is a schematic which shows the connection between the control/monitor circuit and the HVPS, the interlock, and the alarm.

J4 connects the control/monitor circuit and the HVPS. Pins 1 and 2 carry the power (12 VDC) to the HVPS. Pins 3 and 4 are ground. Pins 5 and 6 are analog signals, inputs to the HVPS which set the current and HV bias respectively. They are produced by DACs in the control and monitor circuit. Pins 7 and 8 are logic signals; pin 7 is an output from the HVPS indicating that it is functioning properly while pin 8 is an enable to the HVPS. Pins 9 and 10 are analog signals, output from the HVPS indicating the HV bias and current respectively.

For the HVPS to turn on there must be power on the power pins, valid voltages on the analog control lines, and the logic enabled. The HVPS then produces three outputs read by the monitor circuit. Key issues for the safety interlock are the following:

- 1) The interlock is the connection between pins 1 and 2 of J3. This connection carries the 12 VDC power supply current to the HV supply. If the interlock is opened, the HV supply is powered off so cannot operate. This is important because it guarantees that the HVPS will turn off when the interlock is opened: there is no other path to supply power to the HVPS.

Note that the interlock carries the full supply current, so long wires are not recommended. If the interlock will be operated from a remote switch, we recommend having the switch operate a relay located close to the Mini-X.

Note also that these pins can provide the power to the HVPS and to the monitor/control circuits. For customers who do not want to use the AC/DC supply provided by Amptek, these pins on J3 may be used as an alternate power supply connection. Note that the input power is 12 VDC and must go to both pins 1 and 2 (pin 2 supplies the HVPS while pin 1 supplies the control circuits).

Note also that the user is then responsible for the interlock circuitry.

- 2) If the interlock is opened, U3 is held low, generating the /RESET signal. This signal resets the two DACs used to control the HV and current. These DACs, P/N AD5623, go to zero volts when reset and latch the zero voltage. The Mini-X requires a command be sent over the USB interface to set these to a non-zero voltage.

This is important because this prevents the HVPS from turning back on as soon as power is restored. When the interlock is restored, power is restored to the HV supply but the control inputs are still at zero volts. A command must be sent after the interlock is restored to produce X-rays. This ensures a redundant sequence for turning on X-rays: a hardware switch must be closed and a software command must be issued.

Fig. 15 also shows the how the alarm functions. When the controller brings the control line high, it activates the two 555 timers. One produces a 1.6 Hz signal, the other a 5 kHz signal. These signals control the speaker and the LED on the Mini-X: the LED flashes at 1.6 Hz, and the speaker produces a 5 kHz tone, modulated at 1.6 Hz.

This circuit also produces a 1.6 Hz input to the FET, Q1. This FET can be used to control an external alarm (audio, light, etc.). Please note that there is no heat-sinking on the FET so it cannot dissipate significant continuous current.

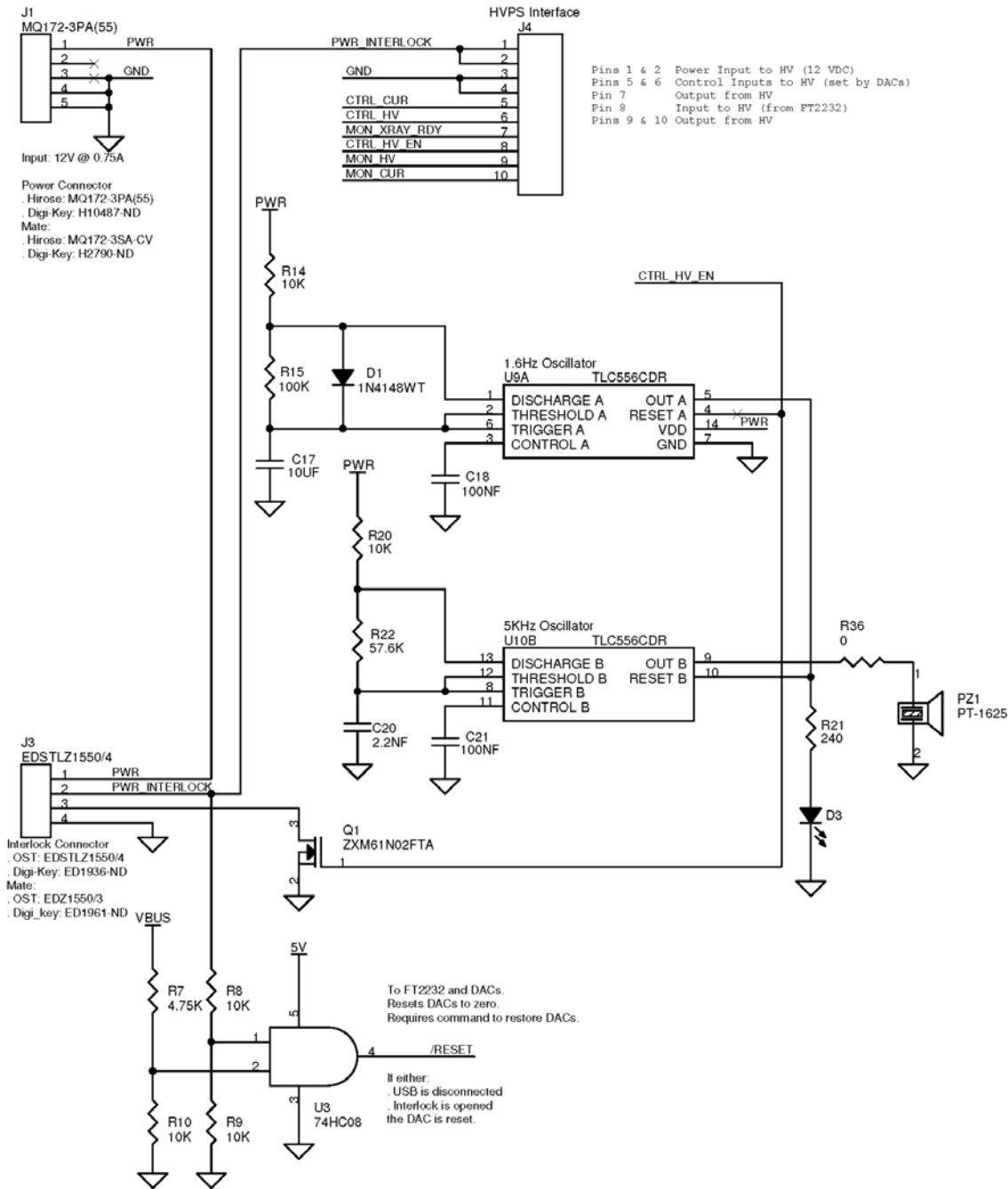

Fig 15. Schematic of the interlock and alarm portion of the Mini-X Control and Monitor circuitry.